

List of Components

RDPS1 Swing Arm Bracket x 1
Fixings x 8
Instruction Manual x 1

Instruction Manual

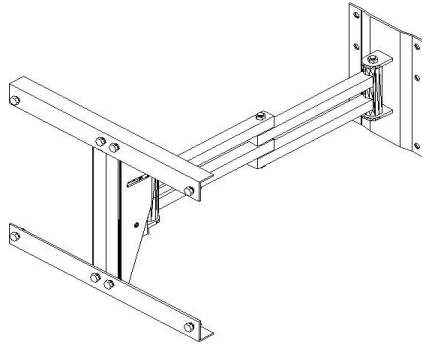

1. Attaching back plate to wall.

Mount wall plate on wall in desired position using screws/ bolts (not supplied) suitable to construction of the wall. (If in any doubt please consult a qualified builder). Attach screws/bolts through all four holes. (If in any doubt as to strength of fixings please consult a qualified builder.)

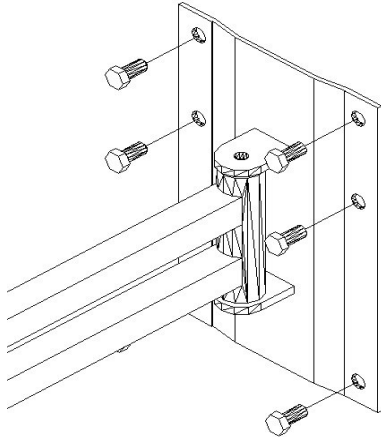

Ensure that all 8 bolts are tightened to the maximum.

2. Attaching back plate of RDPF1 to the Swing Arm Adaptor.

Using the bolts provided attach the back plate to the Swing Arm Adaptor as shown in the illustration below.

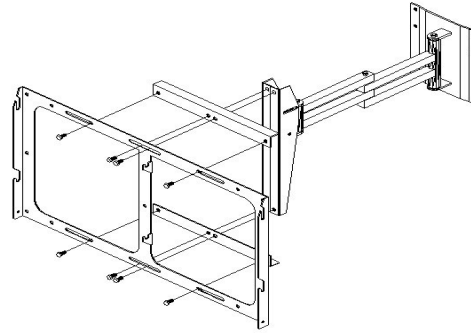

3. Attaching front plates to back plate.

The Swing Arm Adaptor is now ready to engage the screen with the front plates attached to the back plate of the RDPF1. Please refer to section 2 in the RDPF1 instruction manual on how this is done.

